

Seasonal Storage Cost

by *Gerrit Muller* USN-SE

e-mail: gaudisite@gmail.com

www.gaudisite.nl

Abstract

A set of cost models building on the basic models for storing renewable energy to cope with seasonal variations and on the dynamics of the systems and the environment.

Distribution

This article or presentation is written as part of the Gaudí project. The Gaudí project philosophy is to improve by obtaining frequent feedback. Frequent feedback is pursued by an open creation process. This document is published as intermediate or nearly mature version to get feedback. Further distribution is allowed as long as the document remains complete and unchanged.

April 4, 2021
status: preliminary
draft
version: 0

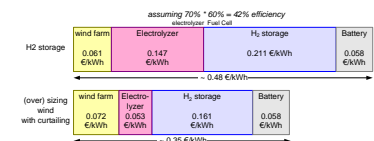

Cost Model; Guestimates, 2019 data

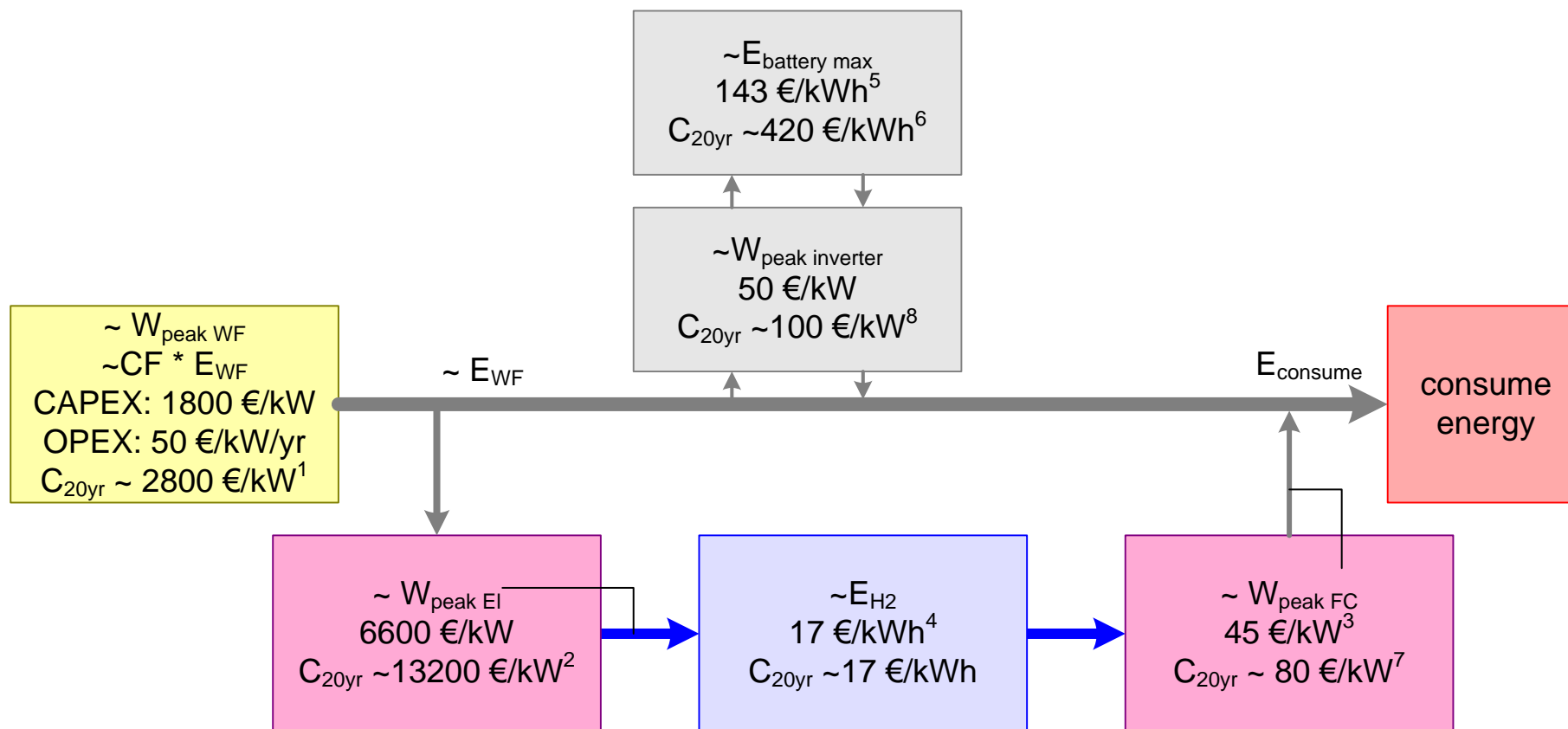

¹ https://www.pbl.nl/sites/default/files/downloads/pbl-2019-costs-of-offshore-wind-energy-2018_3623.pdf

² using 10 k\$ for 1 KG H₂ in 24 hrs, 33.33kWh/Kg H₂, and 0.92 €/€, 30000 hrs \sim 10 years <https://pv-magazine-usa.com/2020/03/26/electrolyzer-overview-lowering-the-cost-of-hydrogen-and-distributing-its-productionhydrogen-industry-overview-lowering-the-cost-and-distributing-production/>

³ <https://www.energy.gov/eere/fuelcells/fact-month-april-2018-fuel-cell-cost-decreased-60-2006>

⁴ <https://energypost.eu/the-lowdown-on-hydrogen-part-1-transportation/>

⁵ <https://www.greencarcongress.com/2019/12/20191204-bnef.html>

⁶ 1000 full cycles, let's assume 7 years,

<https://www.forbes.com/sites/arielcohen/2020/12/30/teslas-new-lithium-ion-patent-brings-company-closer-to-promised-1-million-mile-battery/>

⁷ 40000 hours at -35 °C to 40 °C, \sim 12 years https://en.wikipedia.org/wiki/Fuel_cell

⁸ assuming 10 years <https://www.nrel.gov/docs/fy19osti/72399.pdf>

Energy Cost; Curtailment is Lower in Cost!

assuming 70% * 60% = 42% efficiency
 electrolyzer Fuel Cell

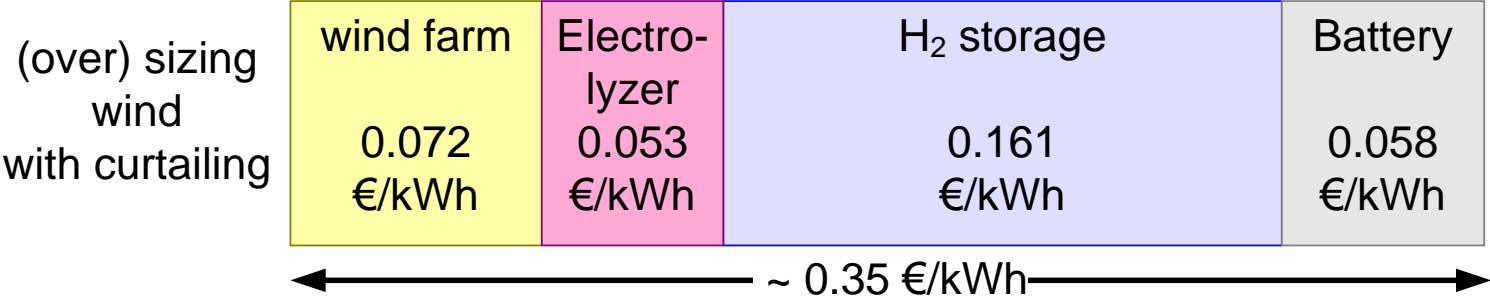
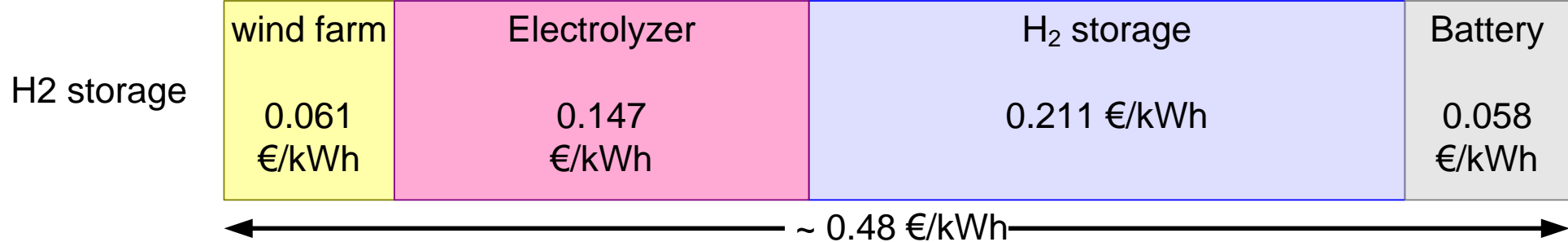

Energy Cost as Function of H2 Size

