

Master Project; PERT plan

by *Gerrit Muller* University of South-Eastern Norway

e-mail: `gaudisite@gmail.com`

`www.gaudisite.nl`

Abstract

A PERT plan primarily shows the logic of the project plan, by showing activities and their relations. There is little or no information on resources and time. A PERT plan is more robust for changes due to project events and it provides a better overview than GANTT charts.

Distribution

This article or presentation is written as part of the Gaudí project. The Gaudí project philosophy is to improve by obtaining frequent feedback. Frequent feedback is pursued by an open creation process. This document is published as intermediate or nearly mature version to get feedback. Further distribution is allowed as long as the document remains complete and unchanged.

September 3, 2021
status: planned
version: 0

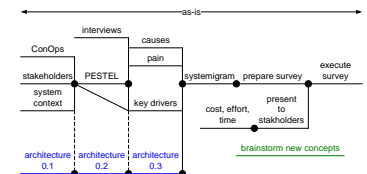

Example PERT Plan

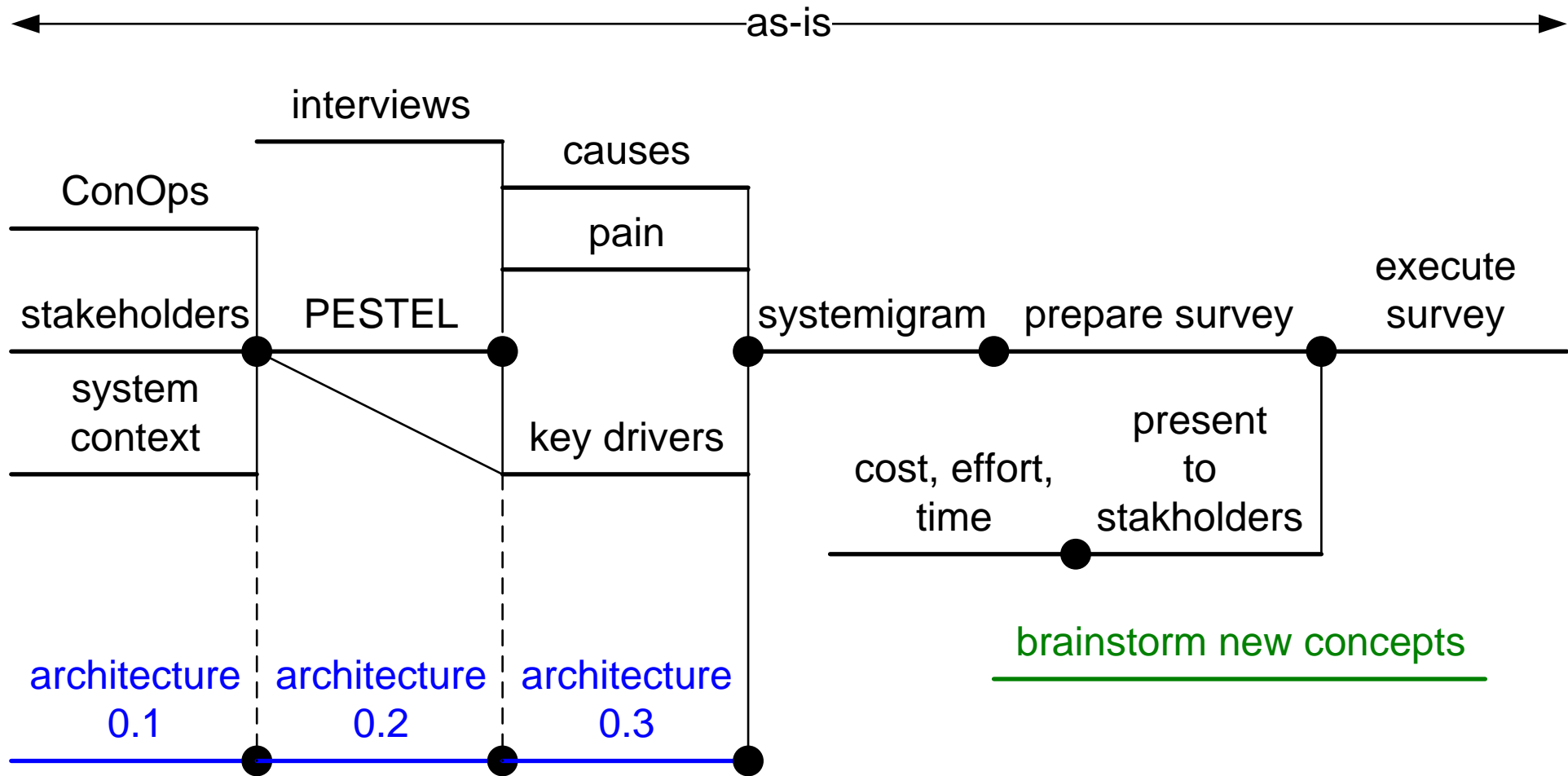

Make a PERT plan for Master Project Execution

- Strive for >20 activities
- Show dependencies

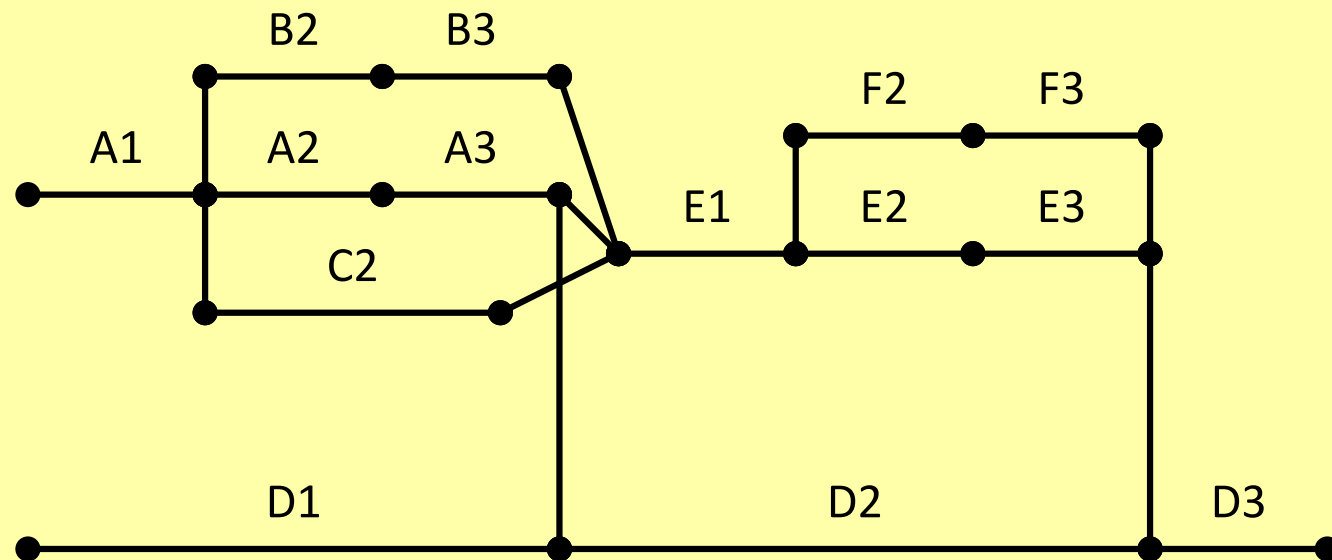

Assess your PERT plan

- How many activities did you define so far?
- How concrete are the activities? [1 = highly generic, 5 is very specific (e.g. system, phase, stakeholder, properties, etc. defined)]