

From System to Ecosystem

by *Gerrit Muller* USN-SE

e-mail: `gaudisite@gmail.com`

`www.gaudisite.nl`

Abstract

OEM vendors sell products that they see as their System-of-Interest. Many capabilities require interaction of multiple products and humans or organizations; we enter here the Systems of Systems (SoS). These SoSs with their associated social entities form even more complex ecosystems.

Distribution

This article or presentation is written as part of the Gaudí project. The Gaudí project philosophy is to improve by obtaining frequent feedback. Frequent feedback is pursued by an open creation process. This document is published as intermediate or nearly mature version to get feedback. Further distribution is allowed as long as the document remains complete and unchanged.

August 9, 2024
status: preliminary
draft
version: 0.1

logo
TBD

Characterization of Domain Layers

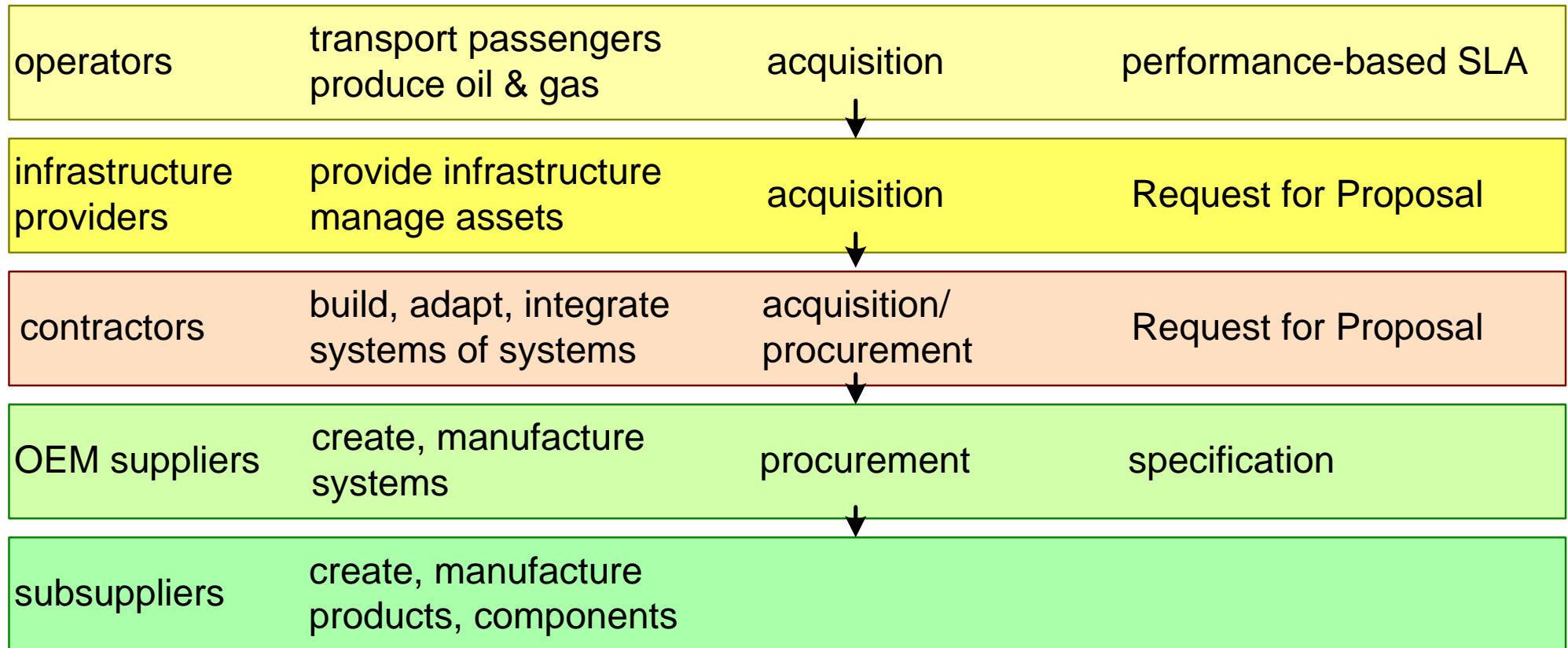

Positions in the Value Network Differ in Nature

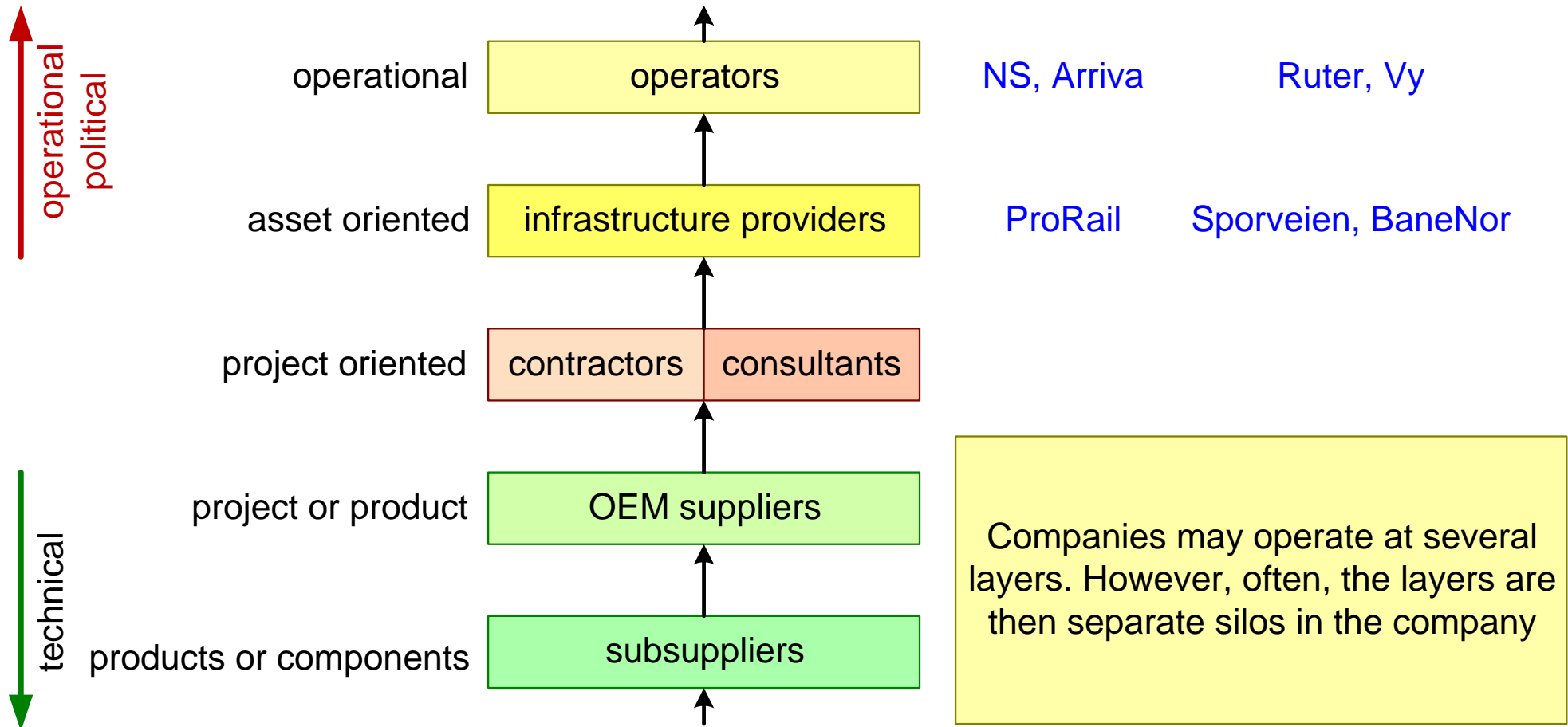

Perspective Changes from Layer to Layer

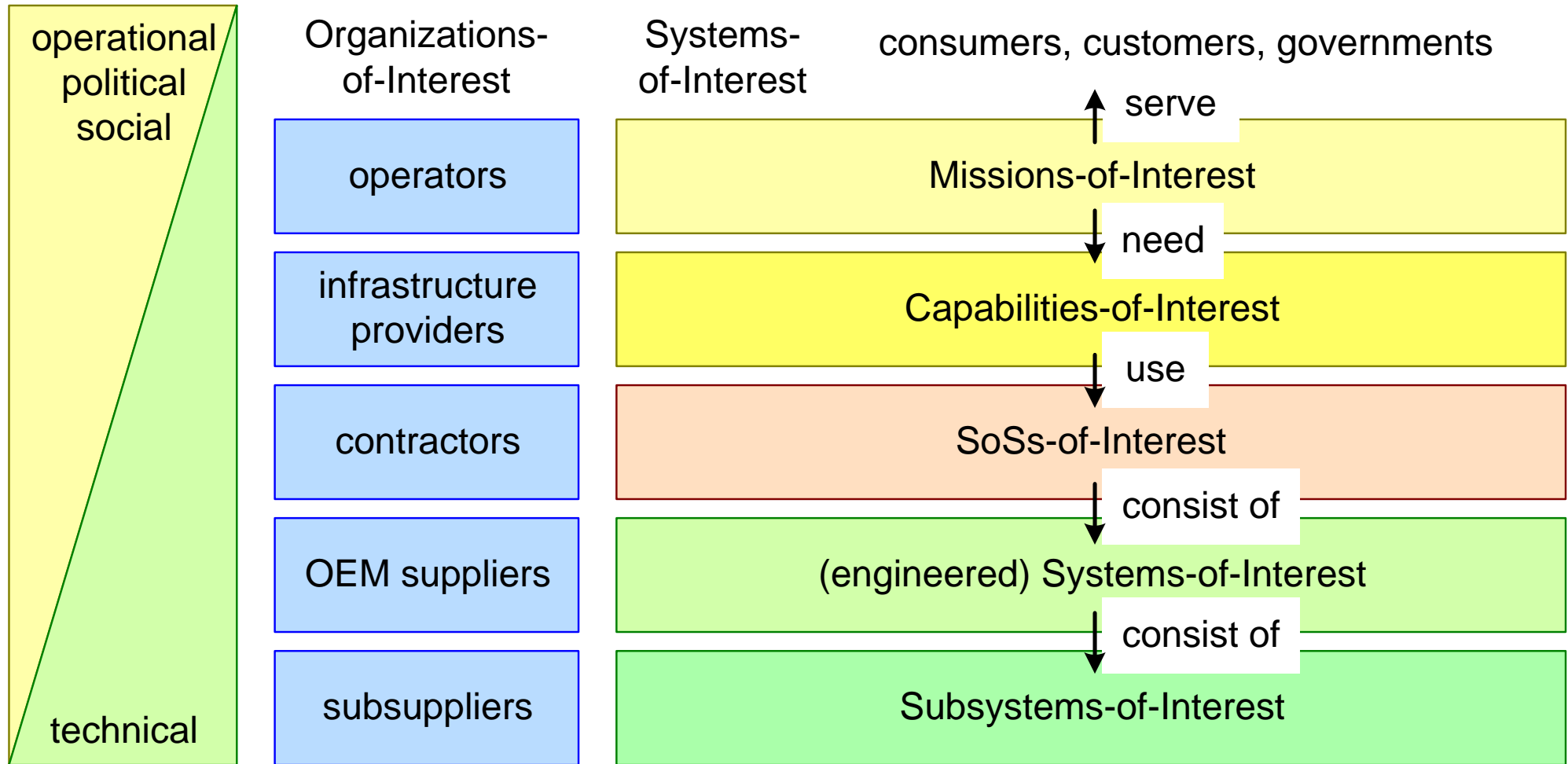

Development Has to Develop the Sol and the Enabling Systems

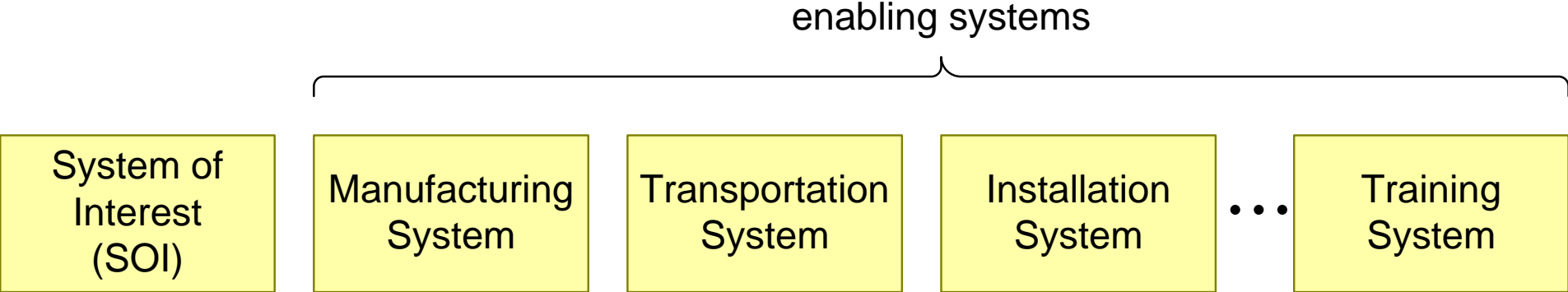

Development and Engineering must develop the System of Interest and all Enabling Systems

The Level of Influence Decreases with Scope

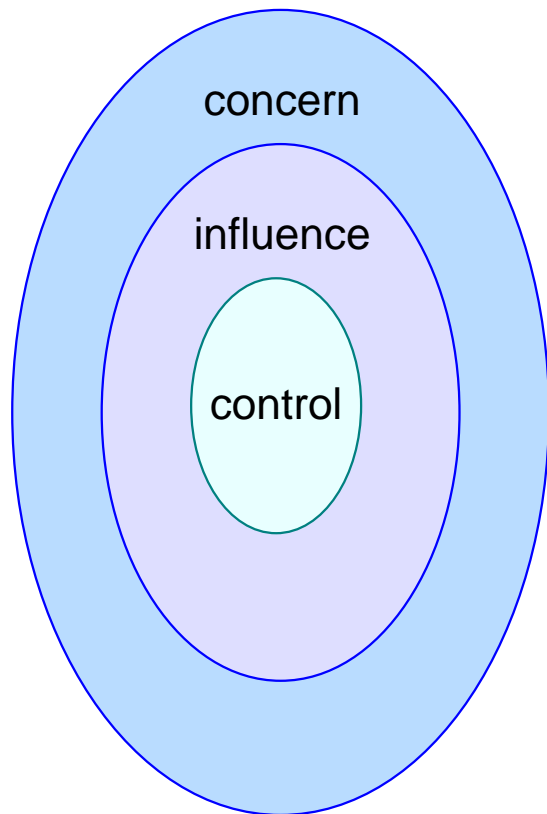

framework after
"The 7 Habits of Highly Effective People.",
Stephen Covey

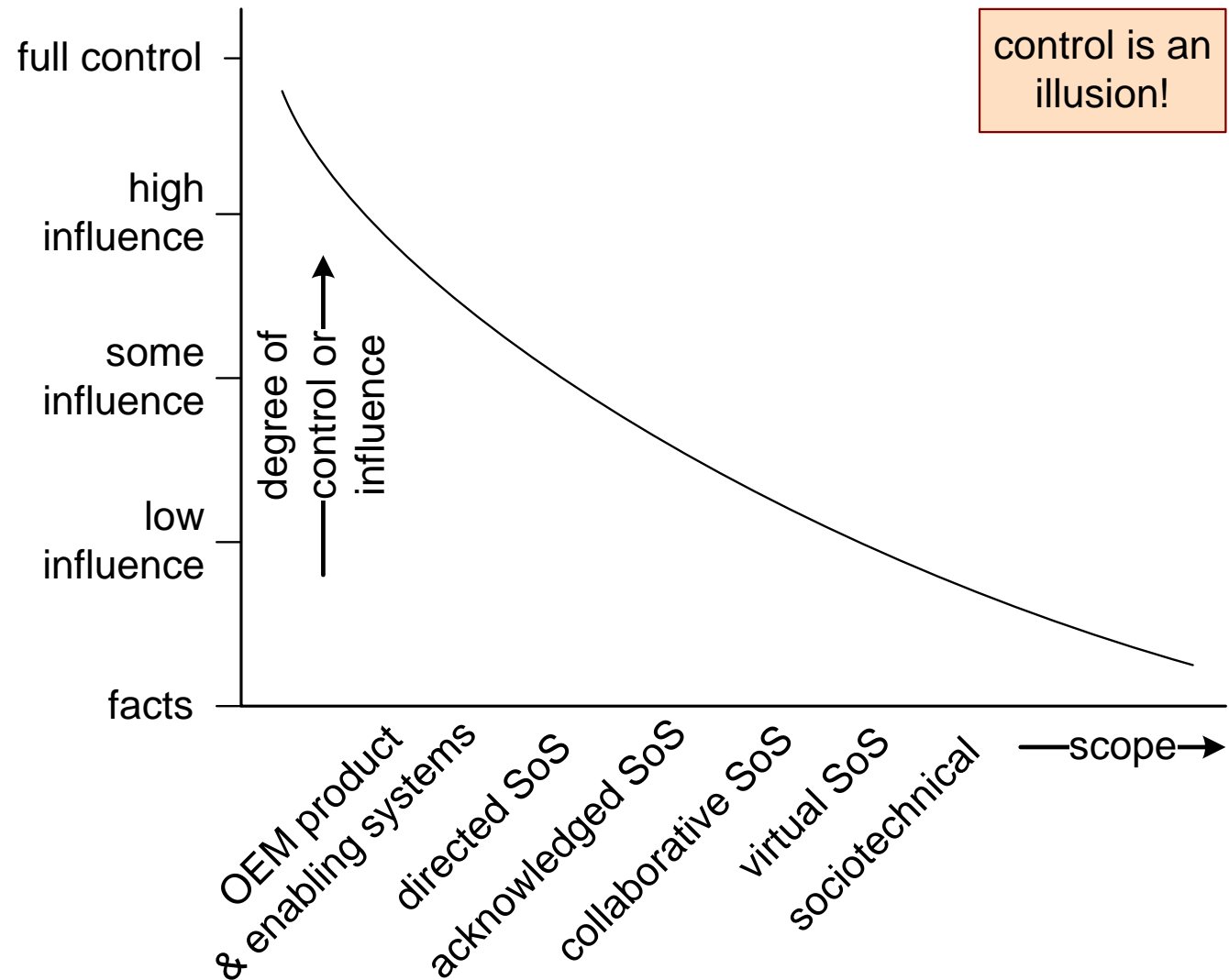

Each System is Part of its Ecosystem

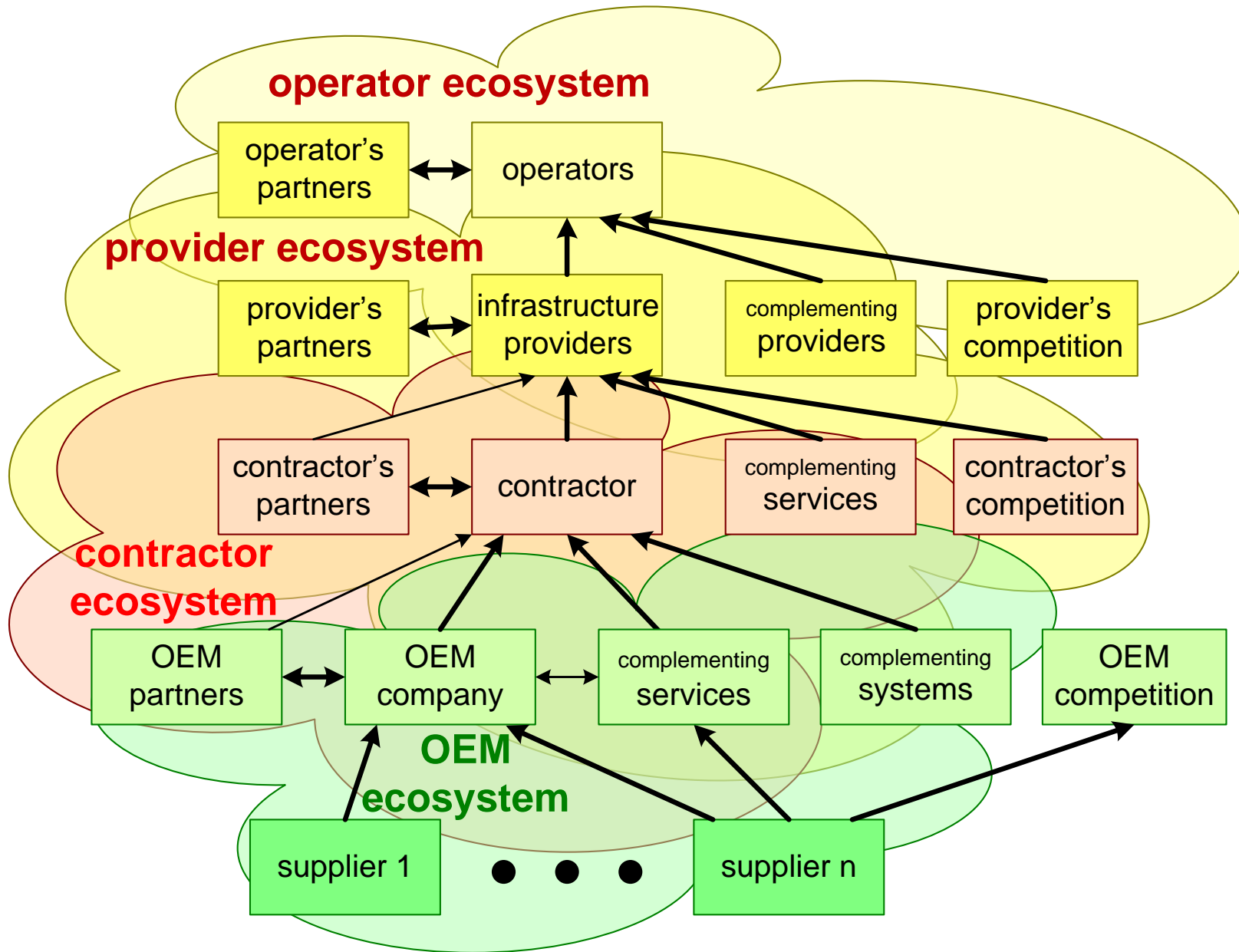

USN-SE and TNO-ESI Experience of the past 24 Years

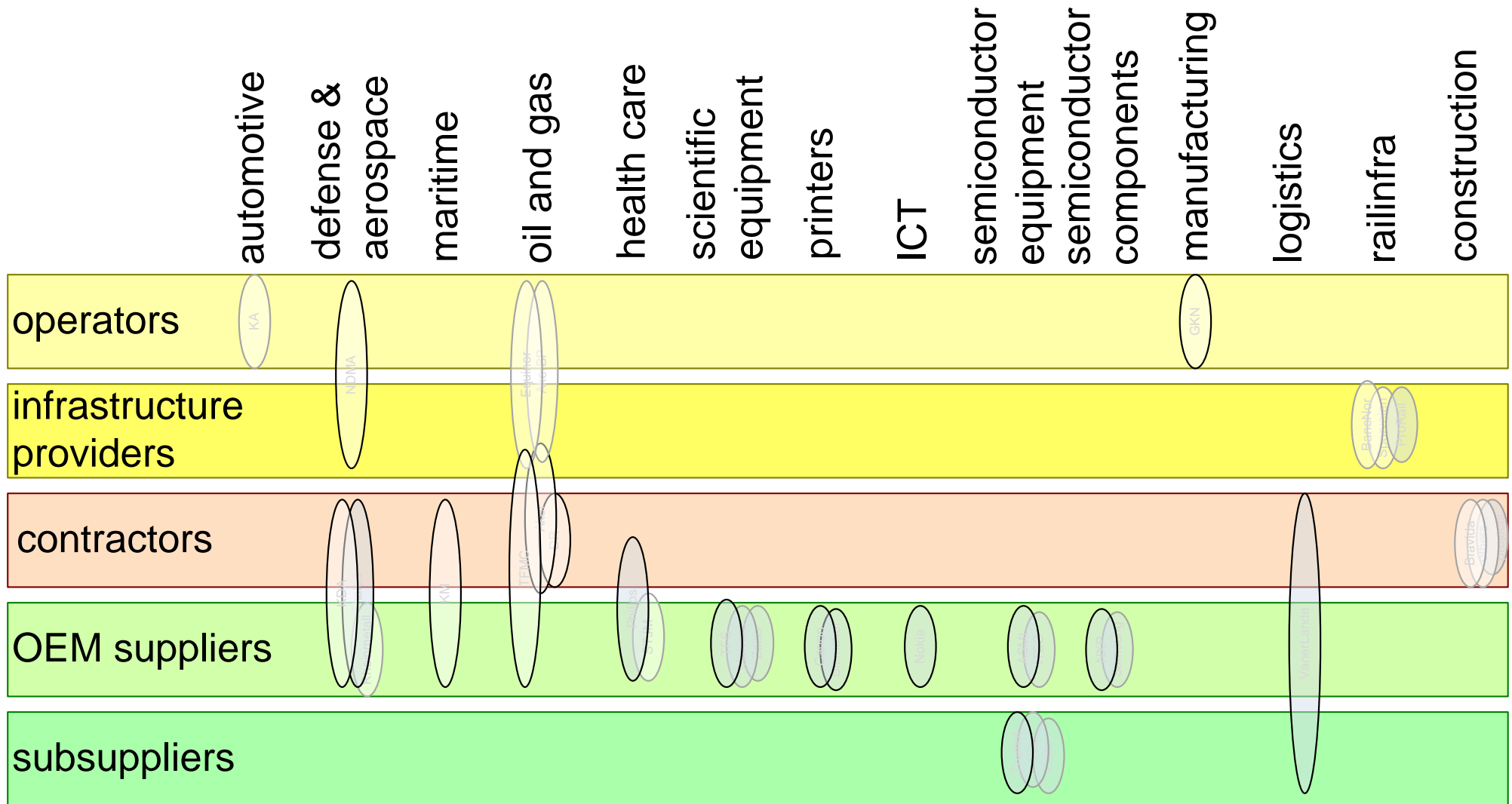

Example Solar Domain

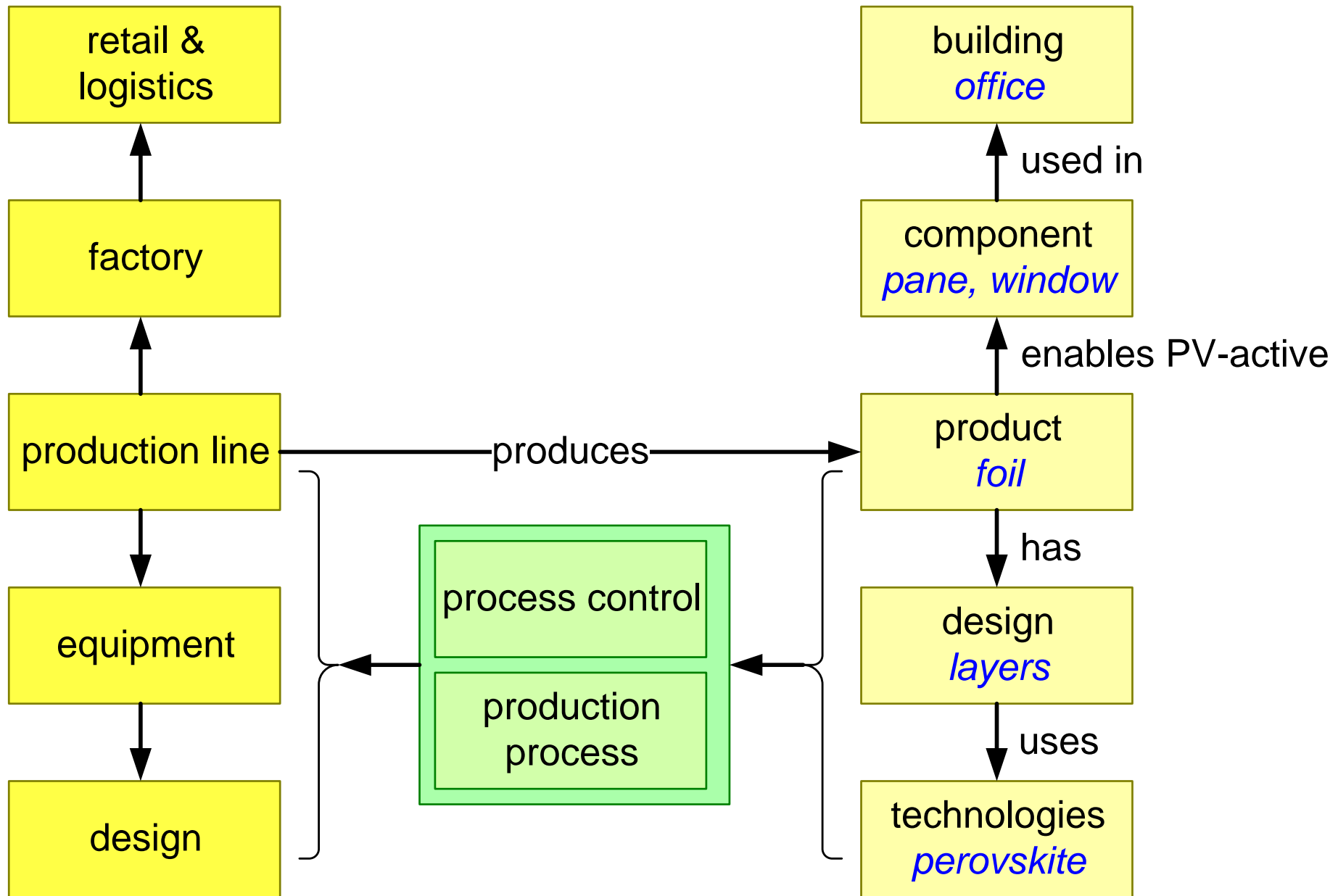

Layers in Solar example

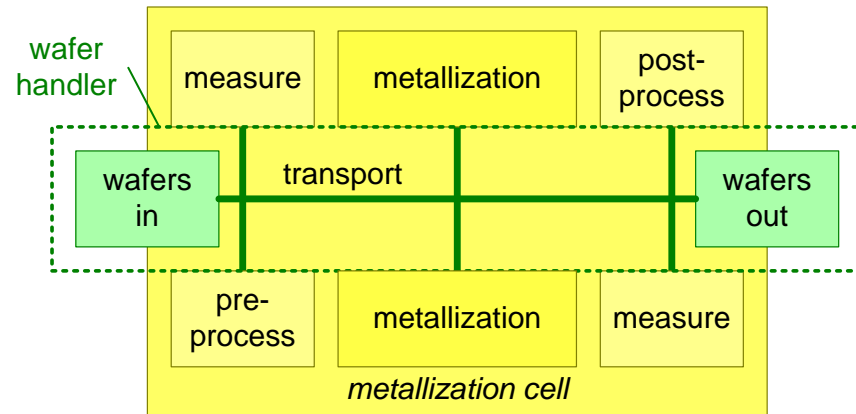
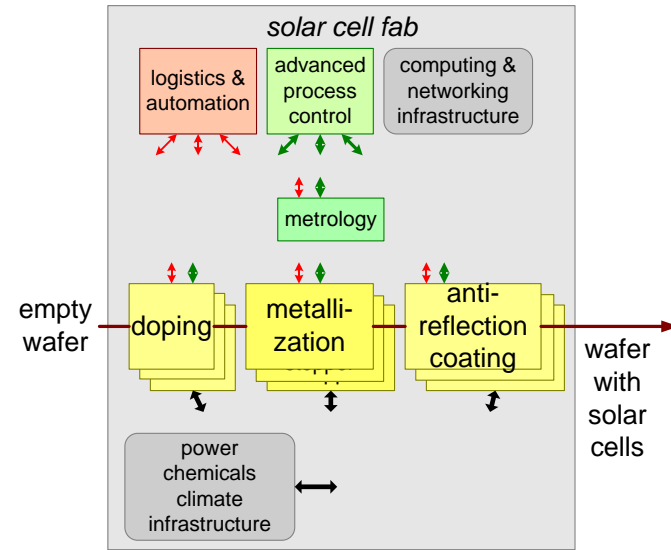
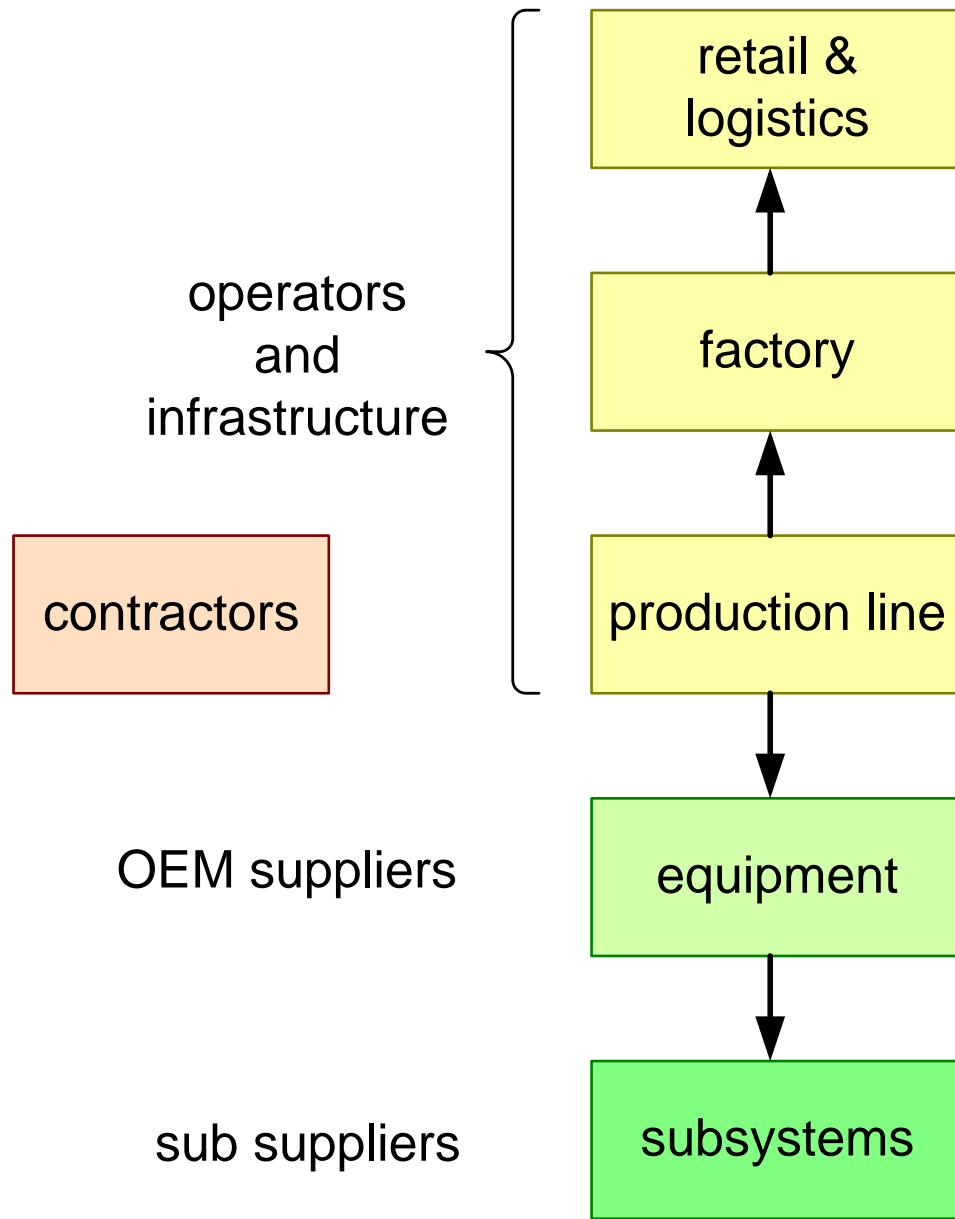

<https://www.gaudisite.nl/SolarCaseSESlides.pdf>

Example in Oil and Gas Offshore

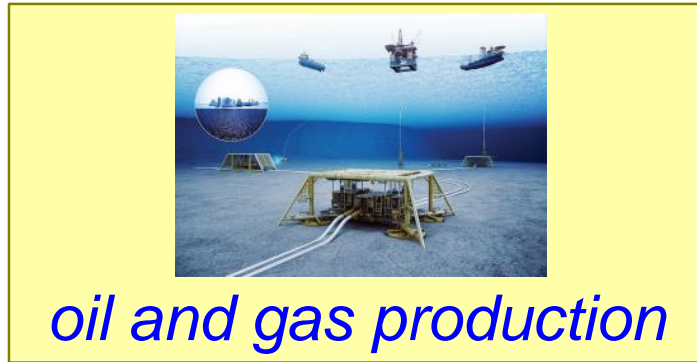

operational

Equinor, Shell

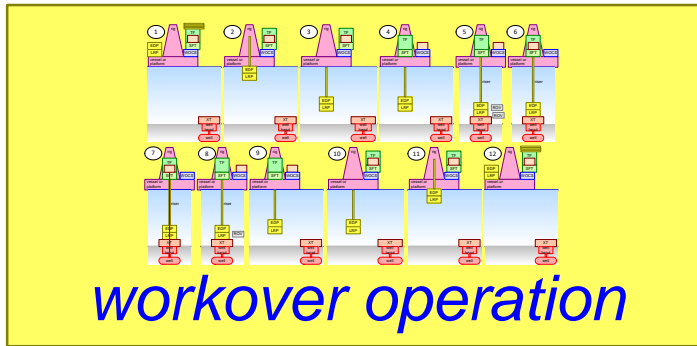

asset oriented

Equinor, Shell

TechnipFMC



project or product

TechnipFMC

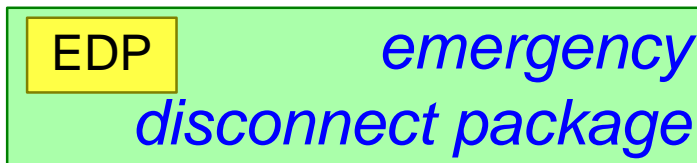

product

TechnipFMC

Example in Semiconductor Industry

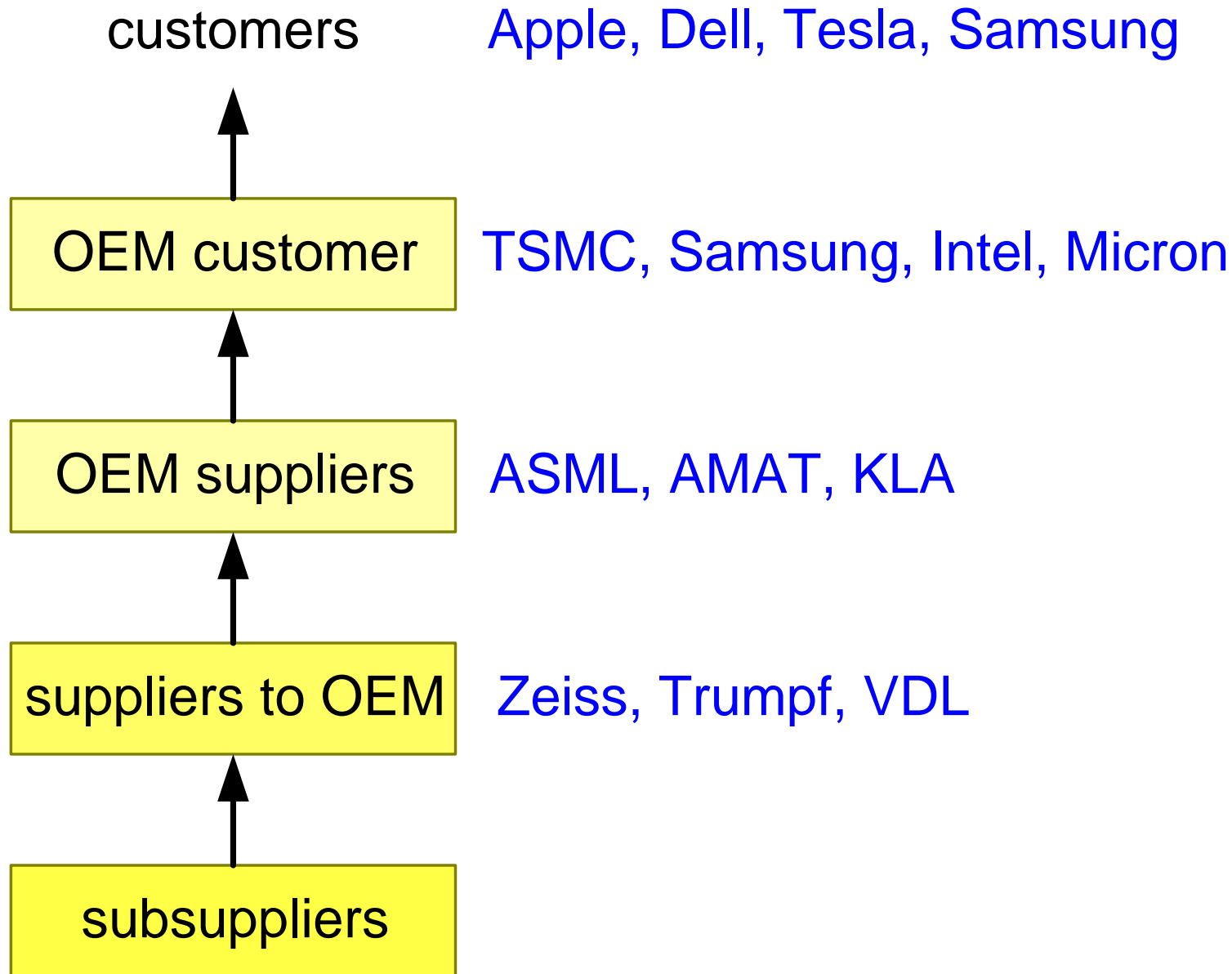

Railways Provider: Focus on Assets and Traffic

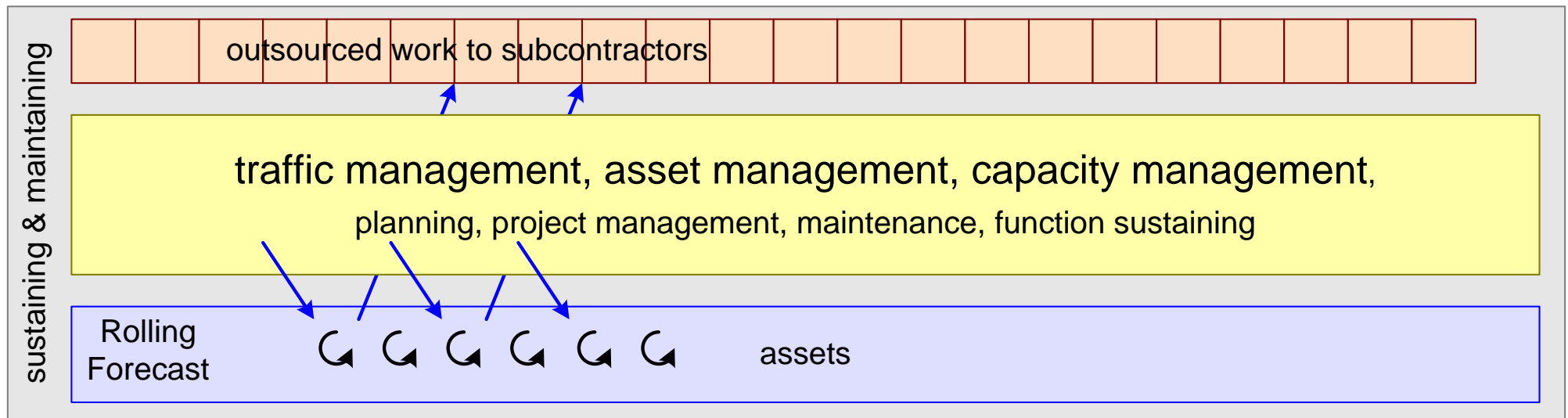

Railways Provider: Program Development

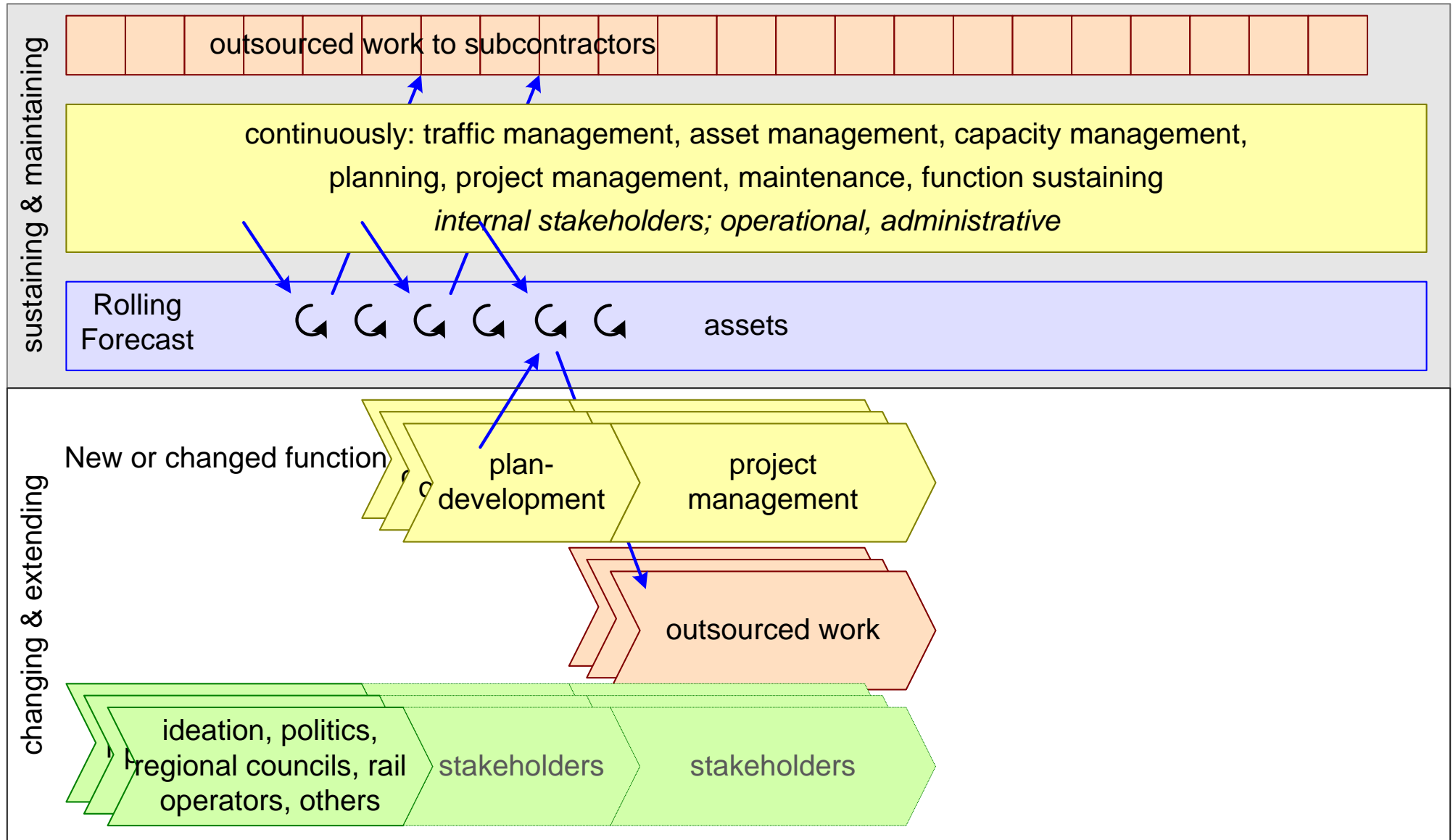

The Value Chain across the Layers

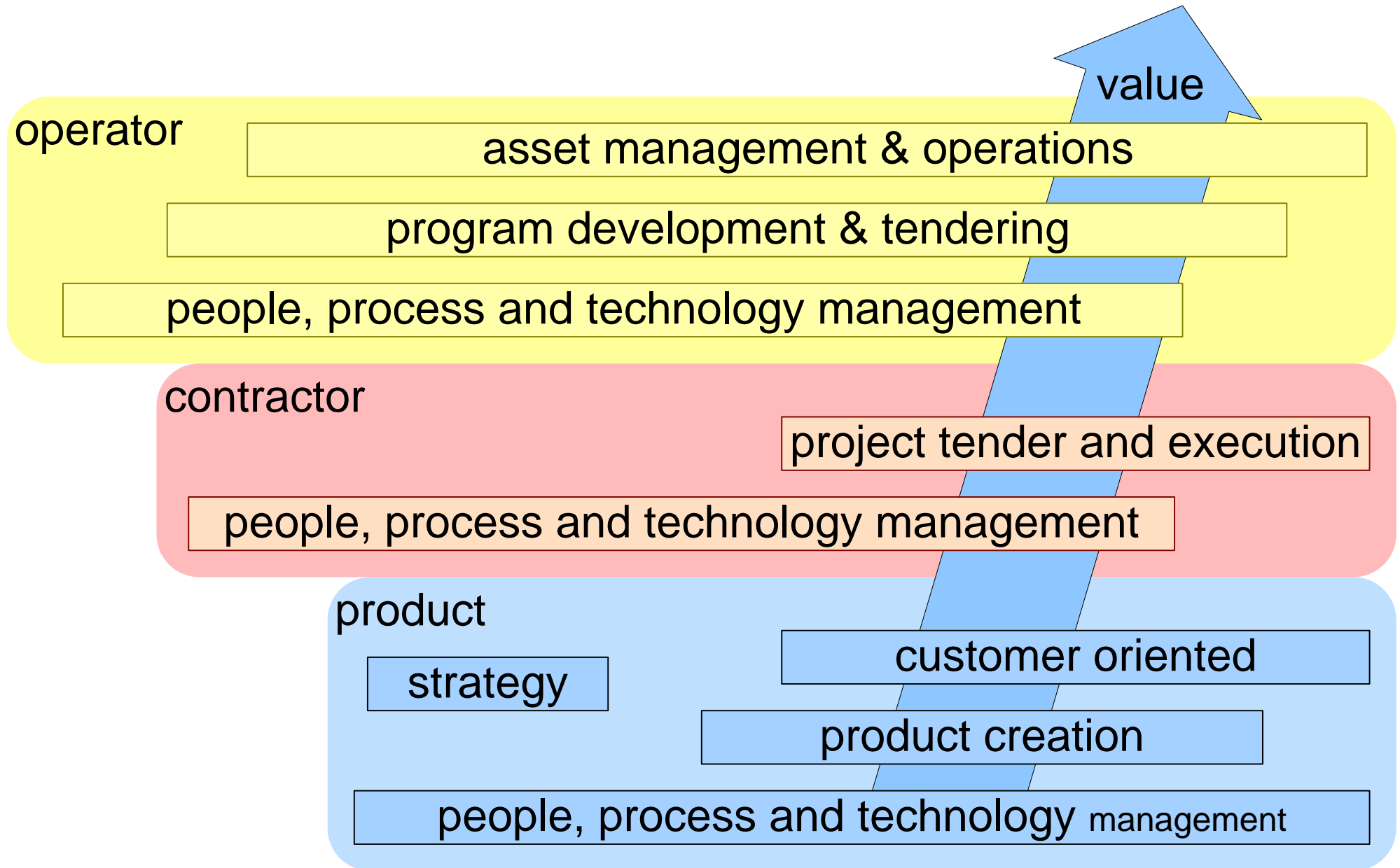

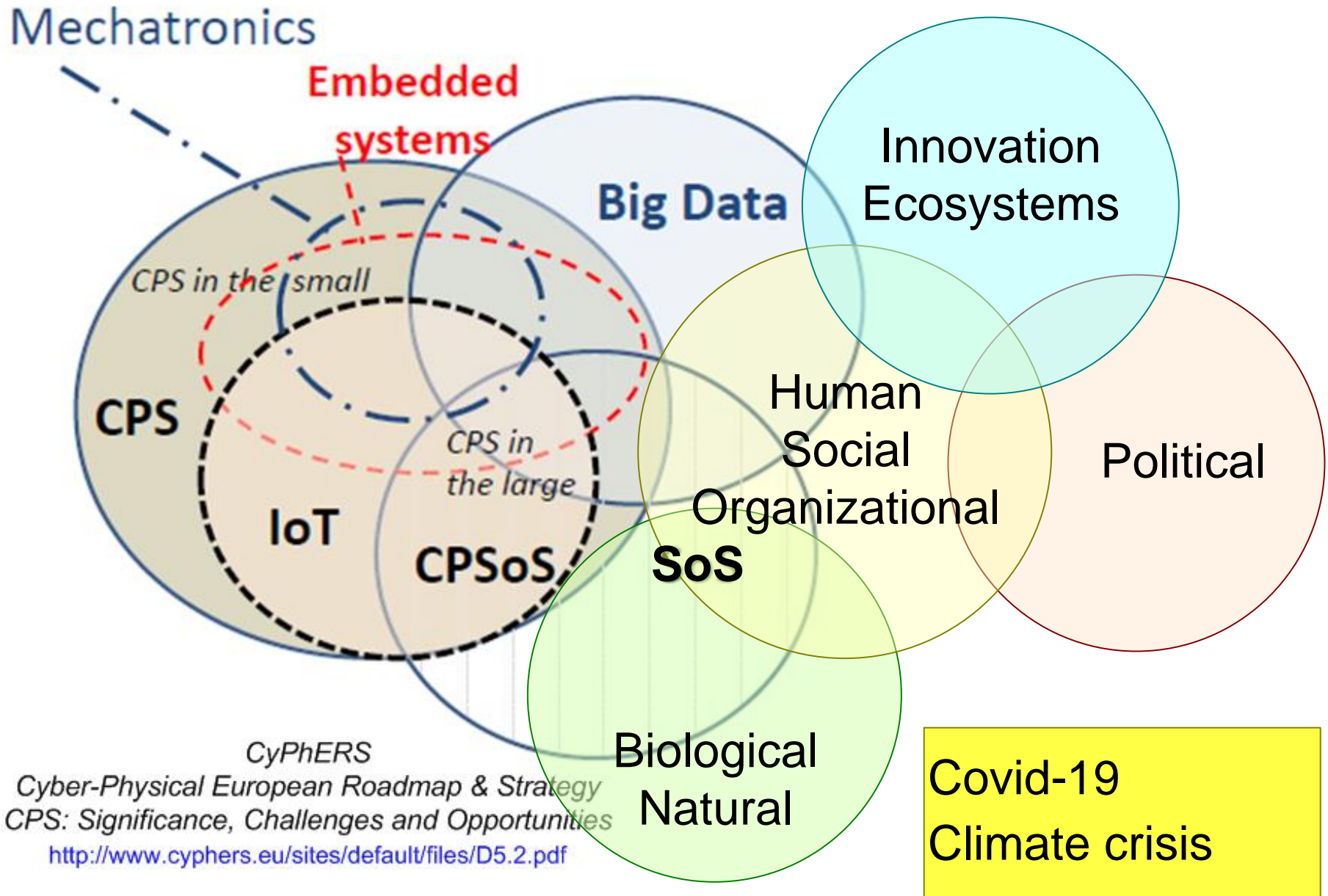

CyPhERS
 Cyber-Physical European Roadmap & Strategy
 CPS: Significance, Challenges and Opportunities
<http://www.cyphers.eu/sites/default/files/D5.2.pdf>